

Features

- Ditch magnets are used in drilling fluid recirculating operations.
- Drilling fluids are pumped to the surface, where cuttings and ferrous metal debris are extracted and captured so that the fluids can be treated for viscosity and recirculated downhole.
- Ditch magnets are designed to remove ferrous metal debris as part of the fluid surface treatment system. If the metal debris is not removed from the drilling mud, it is recirculated and reintroduced downhole when the fluids are recycled, resulting in damage to drill bits, pumps and pose general obstruction.



Lifton Standard and Easy Clean ditch magnets fully made from Stainless Steel are suitable for easy tramp removal from such harsh environments.

Applications

- Just place the ditch magnet in the desired location and wait for it to perform its miracle.
- Depending upon the degree of tramp concentration, the ditch magnet may be required to be removed for cleaning once a day or more.
- If it is desired to ease the process of tramp removal, the Easy Clean model may be suitable.
- If longer lengths are required, these modules may be combined back to back upto any desired length.
- All units c/w lifting Eye-bolt for easy handling & also for cartridge removal in the Easy clean model.

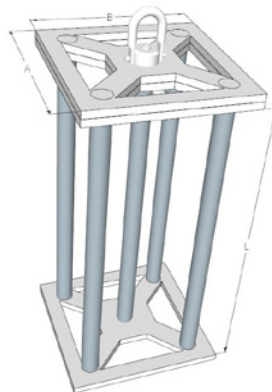
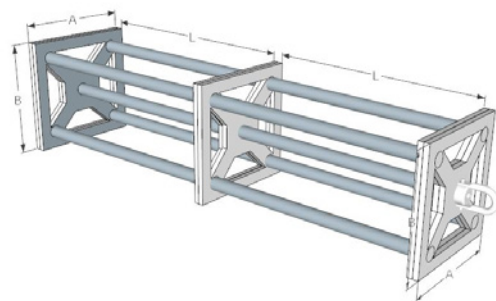

Product Code: DM All dimensions are in mm

Model No.	Dimension (mm)		
	A	B	L
DM-S-300	200	200	380
DM-S-450	200	200	450
DM-S-500	200	200	500
DM-EC-300	200	200	380
DM-EC-450	200	200	450
DM-EC-500	200	200	500

