

# TURBO MAX-DUBLE'

EPM

QUICK SETUP, MULTI-PURPOSE ELECTROPERMANENT MAGNET CLAMP

## FEATURES

- A special variation of the Turbo Max-Mill.
- Magnetic Power over 80 MT/SqM.
- Energy saving design : Electricity is required only for ON/OFF.
- Both primary faces are magnetic. The bottom face clamps to the steel platform or machine table. The top face clamps the job.
- Quickest setup time for drilling, welding, or unique clamping applications.
- Flexibility is maximum as the unit can be positioned anywhere on the table with ease.
- Waterproof construction, can be designed for 110/220/440 VAC, 2-15 Amp.

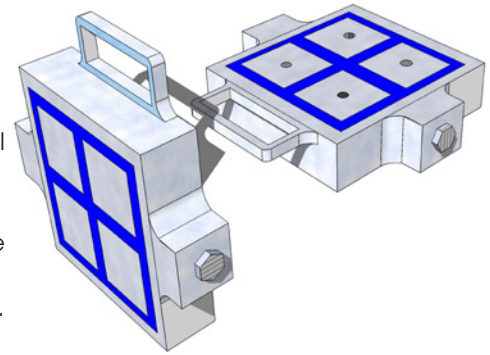

Product Code : EPMD

Model No.	L	W	T	Weight
50 X 50MM SQ POLE			Height without extension block	Weight of the module in Kgs
DUO-50	170	110	50	7
QUADRO-50	170	170	50	10
HEXIO-50	230	170	50	14
SOLO-50	Specify no. of squares	110	50	~
75 X 75MM SQ POLE				
DUO-75	220	135	65	11
QUADRO-75	220	220	65	22
HEXIO-75	305	220	65	31
SOLO-75	Specify no. of squares	135	65	~

Dimensions are non-binding, in 'mm' and can be custom designed

## QUADRO

## SOLO

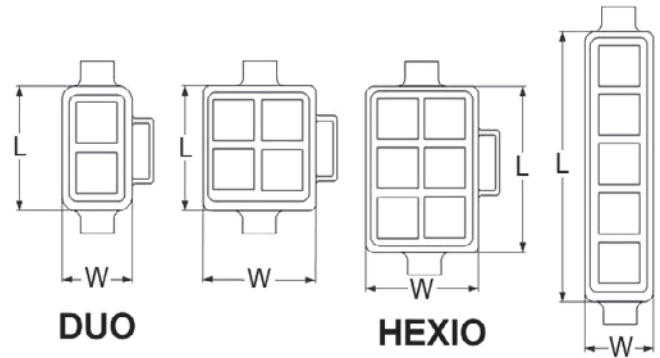

## APPLICATIONS

- Mold base machining .
- Radial, bench, pillar drilling applications.
- Large plate welding & machining applications.

